

Weighbeam DWB 40 ... 200 t



NEW:

- Improved Combined Error: $\pm 0.07\%$
- Improved TK_C Error: $\pm 0.03\% / 10K$

Further Features:

- Six-wire circuit
- Service temperature up to 150°C
- Integrated sensor for temperature monitoring
- Separate mounting of connecting cable through connector

Application

- Ladle turret scales
- Ladle ferries
- Scrap bucket, roller table weighing and tundish scales
- Silo and hopper scales

Construction

- Compact, flat design
- From 50t: Locating head for form locking absorption of side forces
- Plug-in connector

Function

- Simple and economical installation through direct screwing to the connecting structure without movable parts
- No need for additional tie-rods and hold-downs
- Virtually impervious to shock loads and unavoidable side forces
- Suitable to the construction of service free scales in severe environments
- Minimal measurement value reaction on high interferential forces and moments
- High long-term stability
- High degree of repeatability
- Separate mounting of weighbeam and connecting cable possible
- Easy cable exchange

Operating principle

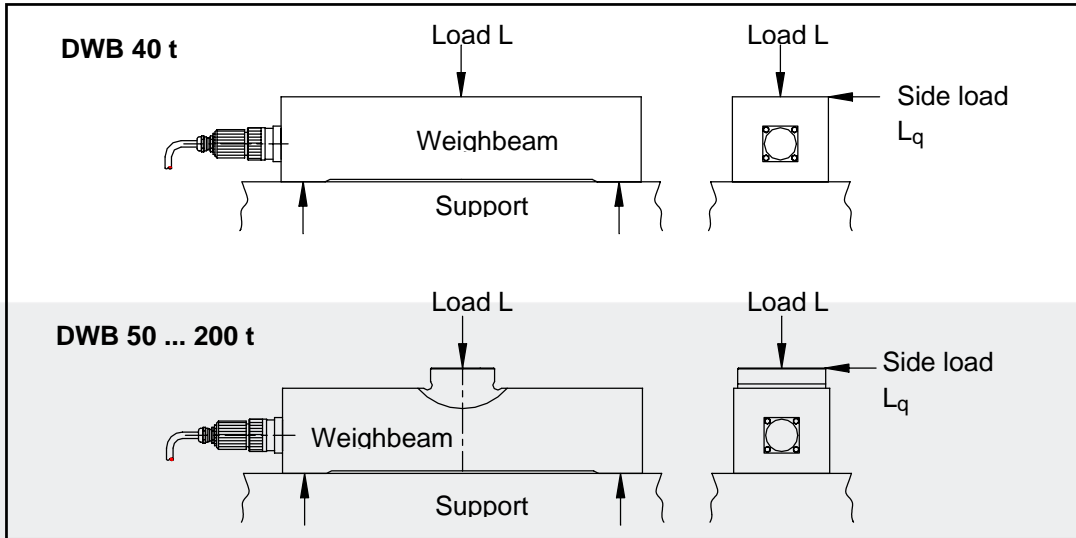

Technical Data

		DWB 40 t	DWB 50 t	DWB 100 t	DWB 150 t	DWB 200 t	Reference
Rated capacity	E_{max}	40 t	50 t	100 t	150 t	200 t	
Limit load (with $L_q=0.15xL_n$) Limit load = Maximum admissible load	L_l	100 t	120 t	210 t	290 t	360 t	
Rupture load (with $L_q=0.15xL_n$)	L_d	160 t	200 t	350 t	480 t	600 t	
Max. admissible side load	L_{qmax}	40 t	50 t	85 t	120 t	150 t	
Sensitivity	C_n	0,95 mV/V	1,08 mV/V	1,38 mV/V	1,57 mV/V	1,63 mV/V	E_{max}
Combined error	F_{comb}	$\pm 0,1\%$	$\pm 0,07\%$				C_n
Creeping under load (30 min)	F_{cr}	$\pm 0,05\%$					C_n
Input resistance	R_e	$756 \Omega \pm 6 \Omega$					T_r
Output resistance	R_a	$700 \Omega \pm 4 \Omega$					T_r
Reference supply voltage	U_{sref}	10V					
Max. supply voltage	U_{smax}	36V					
Nominal temperature range	B_{tn}	- 10°C bis + 100°C					
Service temperature range	B_{tu}	- 15°C bis + 150°C					
Reference temperature	T_r	+ 22°C					
Storage temperature range	B_{ts}	- 50°C bis + 180°C					
Temperature effect on zero signal	TK_o	$\pm 0,05\% / 10K$					C_n in B_{tu}
Temperature effect on sensitivity	TK_c	$\pm 0,03\% / 10K$					
Dead weight	m_e	39 kg	40 kg	55 kg	85 kg	120 kg	
Corrosion protection		hot dip galvanized					
Protection class		IP 65					
Cable specification		Teflon (PTFE) \varnothing 6 mm x 15 m, screened, including plug socket; Bending radius: ≥ 40 mm, Temperature range: -50...+200°C; Wire assignment: 6 wires for measurement value; 2 wires for temperature monitoring					
Colour code		Black: Input + (82) Blue: Input - (81) Red: Output + (28) White: Output - (27) Green: Sense + (82.1) Yellow: Sense - (81.1) Lila / Brown: Temperature sensor PT100					

Mounting Dimensions

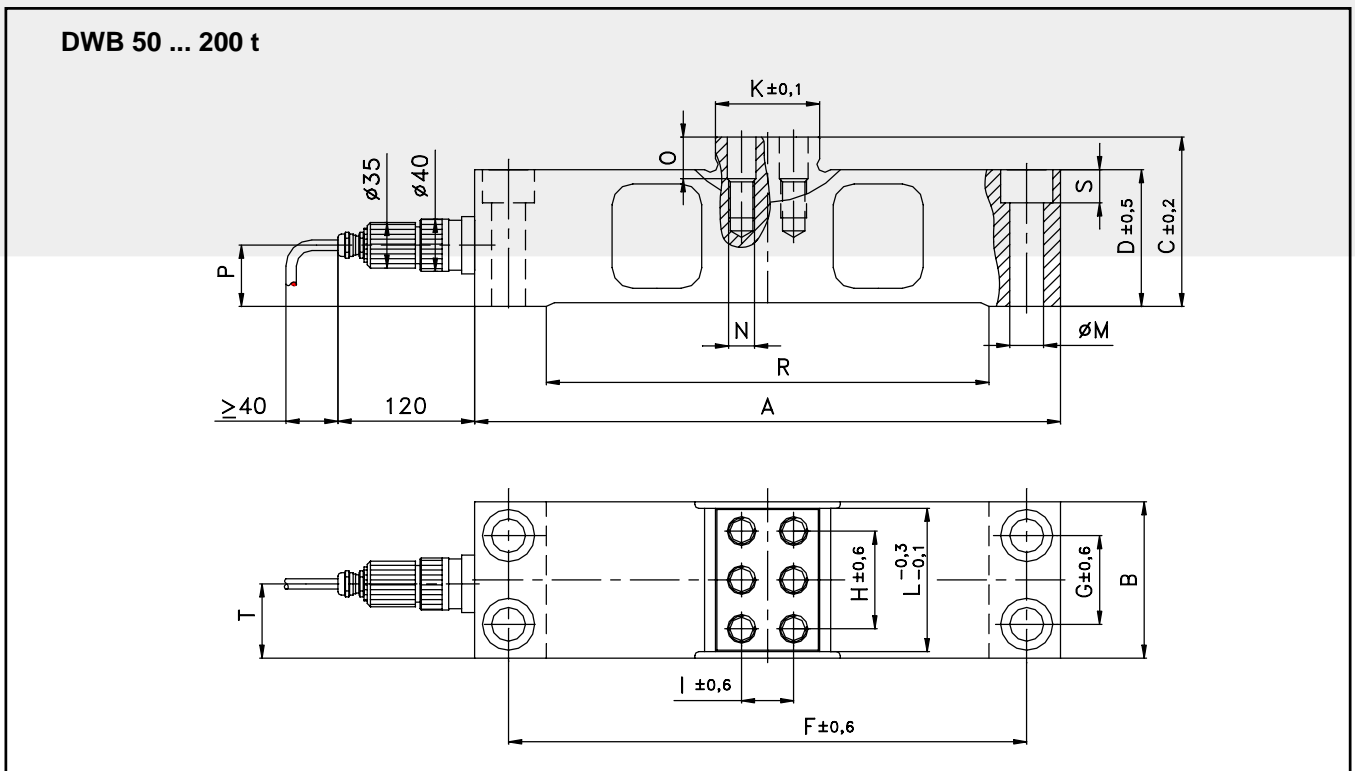

Variant	A mm	B mm	C mm	D mm	F mm	G mm	H mm	I mm	K mm	L mm	M mm	N	O mm	P mm	R mm	S mm	T mm
DWB 50t	450	120	130	105	398	68	75	40	80	110	26	M20x30	32	45	340	25,5	57
DWB 100t	500	140	143	118	444	80	90	44	90	130	30	M24x36	38	54	370	28,5	62
DWB 150t	560	160	158	133	500	94	102	44	90	150	33	M24x36	38	66	410	32	69
DWB 200t	620	180	175	150	560	114	110	44	90	160	33	M24x40	40	75	450	32	76

Connecting surface quality requirements

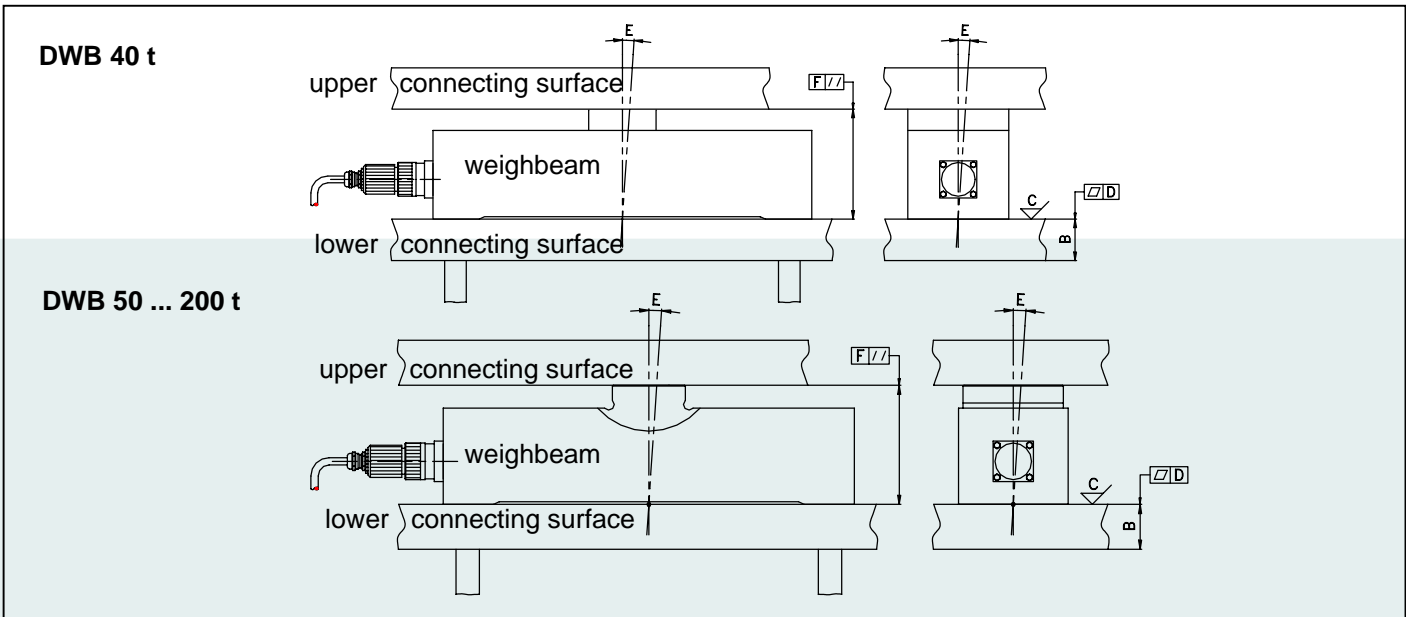

- Material quality "A": Usually construction steel of a minimum quality S355 is used
- Plate thickness "B": Depends on stiffness of total construction. Plate thickness of connecting surface must be at least 40% of the weighbeam height
- Surface quality "C": Requisite mean roughness of the connecting surfaces is 6.3 μm
- Planeness "D": Maximum admissible planeness tolerance within every connecting surface is 0.05 mm
- Angular deviation error to vertical axis "E": Angle deviation of connecting surface to vertical axis in both planes of view must not exceed $\pm 2^\circ$
- Plane parallelism "F": Upper and lower connecting surfaces to the weighbeam have to be plane parallel to minimum 0.1 mm

Variant	Order No.	Variant (*)	Order No.
DWB 40 t	D 726 615.01	DWB 40 t PUR	D 726 615.06
DWB 50 t	D 726 615.02	DWB 50 t PUR	D 726 615.07
DWB 100 t	D 726 615.03	DWB 100 t PUR	D 726 615.08
DWB 150 t	D 726 615.04	DWB 150 t PUR	D 726 615.09
DWB 200 t	D 726 615.05	DWB 200 t PUR	D 726 615.10
<u>Spare Part:</u> High temperature connecting cable 15 m with plug socket	D 726 614.01	<u>Spare Part PUR:</u> (*) connecting cable for outdoor use 15 m with plug socket	D 736 003.01

() Deviant technical data of the PUR variant: suitable for outdoor use (better protection class IP 66), max. service temperature 80 °C, a temperature sensor is not included*

Schenck Process GmbH
Pallaswiesenstr. 100
64293 Darmstadt, Germany
T +49 6151 32-1216
F +49 6151 32-1172
sales@schenckprocess.com
www.schenckprocess.com